

# WinchMaster

SPECIALIST WINCH SOLUTIONS

## SUPERWINCH H9W 3.5 Tonne Line Pull Hydraulic Worm Drive Recovery Winches

### FEATURES INCLUDE:

- **Winch**  
*Compact size & robust construction*
- **Gearbox**  
*High duty, steel centred aluminium bronze wormwheel and casehardened precision ground worm for optimum reliability*
- **Brake**  
*Irreversible worm set, for substantial reliable braking action*
- **Motor**  
*Rugged, high torque unit of proven reliability*
- **Free spooling**  
*Manual released for rapid rope pay-out*
- **Drum**  
*Heavy duty fabricated steel assembly mounted on maintenance-free plain bearings*
- **Testing**  
*All winches are load tested before shipping*
- **12 months warranty**  
*On parts and service (excluding wire rope)*
- **Fitting service**  
*Full or partial fitting can be provided, including load testing and certification*
- **After sales service**  
*Technical advice given on winch fitting and component replacement, plus efficient overnight parts despatch and fast repairs*

### A SUPERWINCH DISTRIBUTOR WITH THE EMPHASIS ON TECHNICAL EXPERTISE

Professional operators want the best technical advice when selecting a winch. They need to be sure that the product they buy is the safest and most suitable for the job, providing complete reliability and minimal vehicle down time.

Winchmaster sales engineers provide valuable advice and guidance, plus a comprehensive winch installation service. They pride themselves in giving a comprehensive parts backup – with next day delivery throughout the UK.

**A service that sets Winchmaster apart from other Superwinch dealers!**

### APPLICATIONS

*The Superwinch H9W – rugged, and versatile 3500kg worm drive hydraulic winches, engineered to a high quality to ensure reliability during winching operations.*

*Designed to provide Professional Vehicle Operators with a dependable unit for speclift, trailer and flatbed recovery vehicles.*

### OPTIONS

- **Cable tensioner**



**WINCHMASTER** Unit 6 South Orbital Trading Park Hedon Road Hull HU9 1NJ  
T: +44 (0)1482 223663 F: +44 (0)1482 218285

**CALL SALES ON 01482 223663**  
E: [sales@winchmaster.co.uk](mailto:sales@winchmaster.co.uk) W: [www.winchmaster.co.uk](http://www.winchmaster.co.uk)

A DIVISION OF  
**BHW**  
GROUP  
LIMITED

WINCHMASTER IS A DIVISION OF THE BHW GROUP LIMITED REGISTERED IN ENGLAND No. 1342461

WM05/01.09.07



CERT. No. 1769

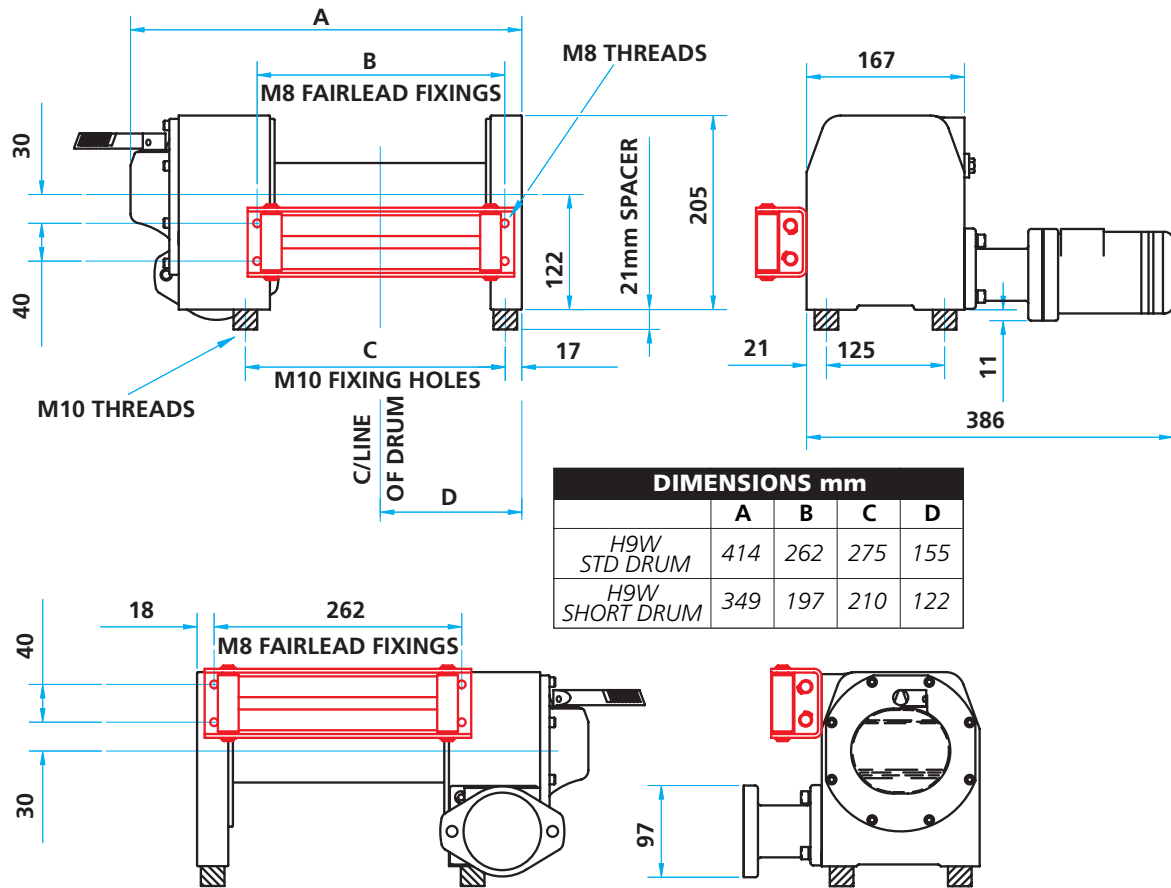

## SPECIFICATIONS

Rated Line Pull, Bottom Layer:

### Short Drum

34kN, (3500kg)

### Long Drum

34kN, (3500kg)

Line Speed, Bottom Layer, No Load:

4.8m/min

4.8m/min

Wire Rope Diameter:

10mm

10mm

Maximum Wire Rope Length:

14m

23m

Rope Drum Diameter:

76mm

76mm

Weight (with roller guides & mounting plate:

40kg approx.

41kg approx.

## PERFORMANCE

Maximum Oil Pressure:

110 bar (1620 psi)

110 bar (1620 psi)

Maximum Oil Flow:

45 l/min

45 l/min

Line Pull, 2nd Layer:

32.5kN, (3320kg)

32.5kN, (3320kg)

Line Pull, 3rd Layer:

27.4kN, (2800kg)

27.4kN, (2800kg)

## WARNING

These winches must not be used for the movement of personnel and 5 wraps of wire rope must be maintained on the drum.

## WARRANTY

Each new winch is guaranteed against defects in workmanship and material defects for a period of twelve months from date of purchase.

**WIRE ROPES ARE NOT INCLUDED UNDER WARRANTY.**