

WinchMaster

SPECIALIST WINCH SOLUTIONS

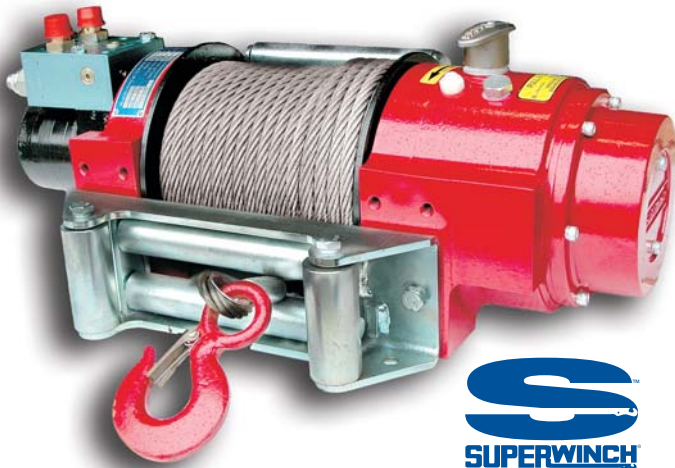

SUPERWINCH H8P/H10P Heavy Duty Hydraulic Planetary Recovery Winches

FEATURES INCLUDE:

- **Winch**
Low profile, robust construction
- **Gearbox**
High efficiency 2 stage planetary drive giving optimum reliability
- **Brake**
Integral, automatic, failsafe
- **Motor**
Rugged, high torque unit of proven reliability
- **Free spooling**
Spring engaged, manual released for rapid rope pay-out
- **Drum**
Heavy duty fabricated steel, mounted on maintenance-free plain bearings
- **Load control valve**
Available with load control valve to ensure complete load control
- **Testing**
All winches are load tested before shipping
- **12 months warranty**
On parts and service (excluding wire rope)
- **Fitting service**
Full or partial fitting can be provided, including load testing and certification
- **After sales service**
Technical advice given on winch fitting and component replacement, plus efficient overnight parts despatch and fast repairs

A SUPERWINCH DISTRIBUTOR WITH THE EMPHASIS ON TECHNICAL EXPERTISE

Professional operators want the best technical advice when selecting a winch. They need to be sure that the product they buy is the safest and most suitable for the job, providing complete reliability and minimal vehicle down time.

Winchmaster sales engineers provide valuable advice and guidance, plus a comprehensive winch installation service. They pride themselves in giving a comprehensive parts backup – with next day delivery throughout the UK.

A service that sets Winchmaster apart from other Superwinch dealers!

APPLICATIONS

The Superwinch H8P/H10P – from the UK's largest winch producer, a rugged, heavy duty, high quality 3,630/4,540 kg planetary drive hydraulic winch, engineered to ensure reliability during recovery and winching operations.

Designed to provide Vehicle Operators with a dependable unit for various winching operations.

OPTIONS

- **Cable tensioner**
- **Pneumatic freespool assembly**

WINCHMASTER Unit 6 South Orbital Trading Park Hedon Road Hull HU9 1NJ
T: +44 (0)1482 223663 F: +44 (0)1482 218285

CALL SALES ON 01482 223663
E: sales@winchmaster.co.uk W: www.winchmaster.co.uk

A DIVISION OF
BHW
GROUP
LIMITED

WINCHMASTER IS A DIVISION OF THE BHW GROUP LIMITED REGISTERED IN ENGLAND No. 1342461

WM07/01.09.07



CERT. No. 1769

Dimensions : mm						
Winch	A	B	C	D	E	F
H8/H10P Short Drum	300	190	591	229	298.5	311
H8P Long Drum	333	253	654	292	361.5	374

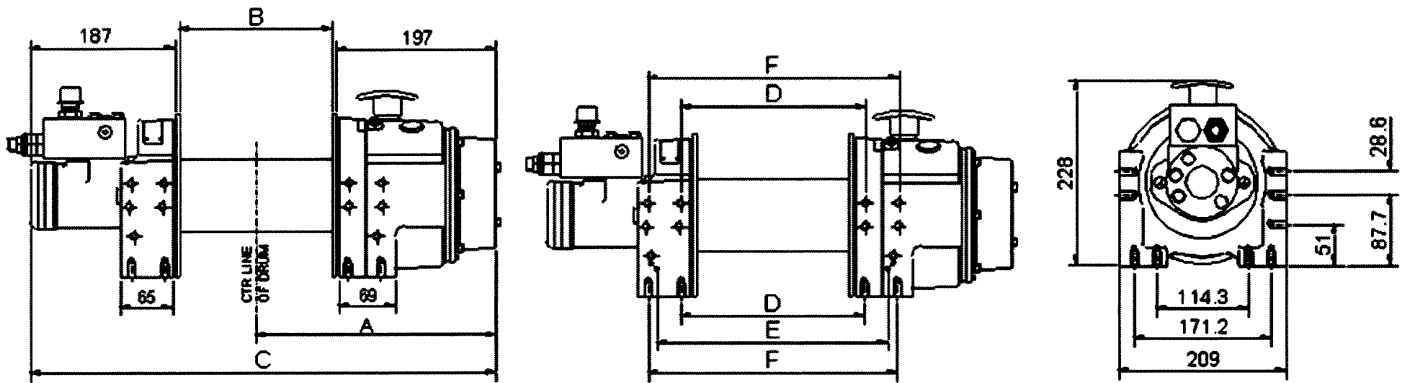

SPECIFICATIONS

Rated Line Pull, Bottom Layer:

H8P

35.6kN, (3,630kg)

H10P

44.5kN, (4,540kg)

Line Speed, Bottom Layer, No Load:

13.8m/min

8.8m/min

Wire Rope Diameter, Recommended:

10mm

11mm

Wire Rope Length, Short Drum:

30m

23m

Wire Rope Length, Long Drum:

40m

N/A

Drum Diameter:

90mm

90mm

Weight Excluding Wire Rope:

38/40kg

38kg

PERFORMANCE

Maximum Oil Pressure:

126 bar (1,850 psi)

126 bar (1,850 psi)

Maximum Oil Flow:

57 l/min

57 l/min

Line Pull, 2nd Layer:

29.6kN, (3,020kg)

36.5kN, (3,720kg)

Line Pull, 3rd Layer:

25.3kN, (2,590kg)

30.9kN, (3,160kg)

Line Pull, 3rd Layer:

22.2kN, (2,260kg)

26.8kN, (2,740kg)

WARNING

These winches must not be used for the movement of personnel and 5 wraps of wire rope must be maintained on the drum.

WARRANTY

Each new winch is guaranteed against defects in workmanship and material defects for a period of twelve months from date of purchase.

WIRE ROPES ARE NOT INCLUDED UNDER WARRANTY.