

WinchMaster

SPECIALIST WINCH SOLUTIONS



SUPERWINCH ATV SERIES 12v DC Winches

FEATURES INCLUDE

- Powers load *IN* and *OUT*
- Mechanical and dynamic brake
- Full metal planetary gear-train
- Freespooling clutch for fast wire rope payout
- High efficiency low amp draw motor
- Heavy duty switching relay sealed to protect against the elements
- Convenient handlebar mounted low amp 'toggle' switch
- Circuit breaker protected
- 15.2m galvanized high tensile wire rope with thimble end and latched hook
- Cable tension plate helps prevent tangled wire rope
- Colour coded wiring for ease of installation
- Roller fairlead standard on ATV2300 and ATV3000
- Hook handling strap
- Mounts quickly with a Superwinch ATV mounting kit
- 12 months warranty
On parts and service (excluding wire rope)
- Fitting service
Full or partial fitting can be provided, including load testing and certification
- After sales service
Technical advice given on winch fitting and component replacement, plus efficient overnight parts despatch and fast repairs

A SUPERWINCH DISTRIBUTOR WITH THE EMPHASIS ON TECHNICAL EXPERTISE

Professional operators want the best technical advice when selecting a winch. They need to be sure that the product they buy is the safest and most suitable for the job, providing complete reliability and minimal vehicle down time.

Winchmaster sales engineers provide valuable advice and guidance, plus a comprehensive winch installation service. They pride themselves in giving a comprehensive parts backup – with next day delivery throughout the UK.

A service that sets Winchmaster apart from other Superwinch dealers!

APPLICATIONS

All terrain vehicles.

OPTIONS

- Accessory kit
- Roller fairlead

WINCHMASTER Unit 6 South Orbital Trading Park Hedon Road Hull HU9 1NJ
T: +44 (0)1482 223663 F: +44 (0)1482 218285

CALL SALES ON 01482 223663
E: sales@winchmaster.co.uk W: www.winchmaster.co.uk

A DIVISION OF
BHW
GROUP
LIMITED

WINCHMASTER IS A DIVISION OF THE BHW GROUP LIMITED REGISTERED IN ENGLAND No. 1342461

WM10/01.09.07



CERT. No. 1769

PERFORMANCE FIRST LAYER OF CABLE

LINE PULL kg	LINE SPEED (approx)			Amp Draw (approx)		
	1800	2300	3000	1800	2300	3000
0	–	–	–	8	8	15
500	227	227	227	30	30	40
1,000	454	454	454	60	60	60
1,500	680	680	680	90	90	100
1,800	816	816	816	108	108	115
2,300	–	1023	1043	–	140	160
2,500	–	–	1133	–	–	180
3,000	–	–	1361	–	–	220

All figures are based on battery maintaining normal voltage.

ATV 1800

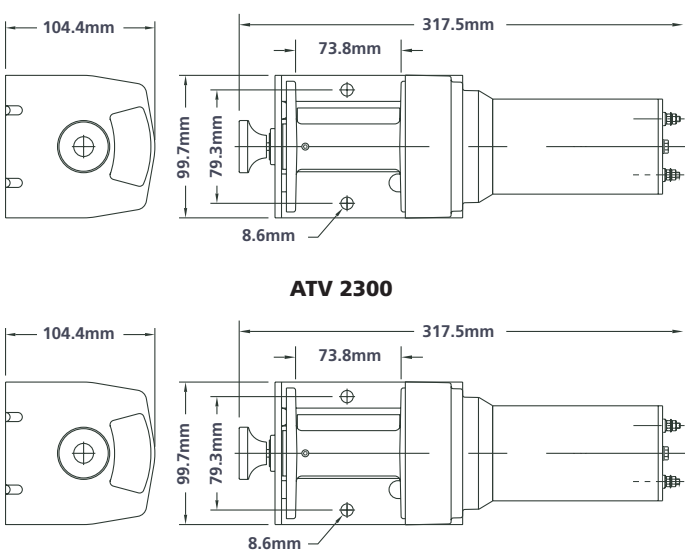

ATV 3000

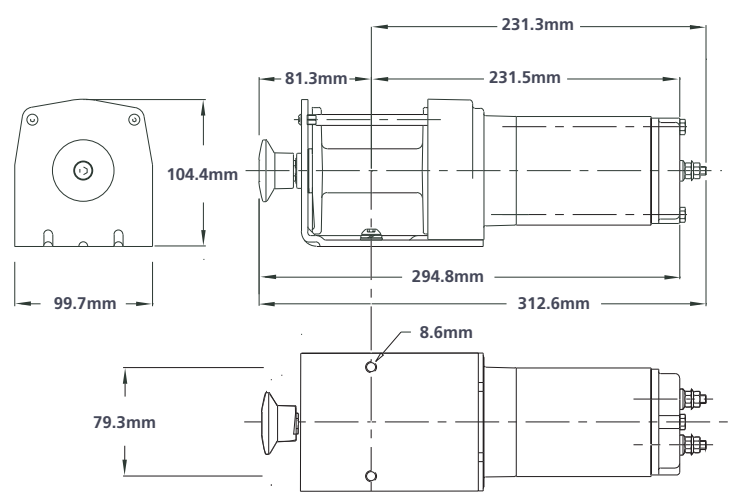

ATV 2300

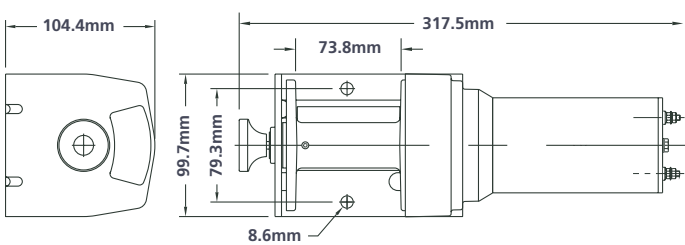

SPECIFICATIONS

	1800	2300	3000
Rated Line Pull (Single Line):	816kg	1,043kg	1,361kg
Motor Series Wound:	0.71hp	0.71hp	1.1hp
Gearing:	Differential planetary	Differential planetary	Differential planetary
Gear Ratio:	153:1	153:1	153:1
Freespooling Clutch:	Pull and turn	Pull and turn	Pull and turn
Braking Action:	Mechanical and dynamic	Mechanical and dynamic	Mechanical and dynamic
Wire Rope with Latched Hook:	3.9mm x 15.2m	3.9mm x 15.2m	4.8mm x 15.2m
Dimensions:	315.7mm x 100mm x 104mm	315.7mm x 100mm x 104mm	322.6mm x 110.7mm x 114.3mm
Drum Diameter:	31.8mm	31.8mm	31.8mm
Drum Length:	73.7mm	73.7mm	73.7mm
Weight:	6.8kg	6.4kg	6.8kg

WARNING

These winches must not be used for the movement of personnel and 5 wraps of wire rope must be maintained on the drum.

WARRANTY

Each new winch is guaranteed against defects in workmanship and material defects for a period of twelve months from date of purchase.

WIRE ROPES ARE NOT INCLUDED UNDER WARRANTY.



WINCHMASTER Unit 6 South Orbital Trading Park Hedon Road Hull HU9 1NJ
 T: +44 (0)1482 223663 F: +44 (0)1482 218285

CALL SALES ON 01482 223663
 E: sales@winchmaster.co.uk W: www.winchmaster.co.uk

