

WinchMaster

SPECIALIST WINCH SOLUTIONS

COMPLIANT WITH EN 14492 REGULATIONS

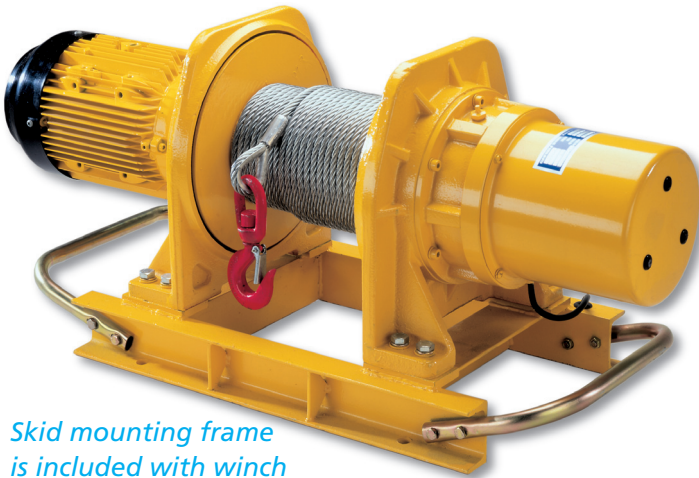

Skid mounting frame is included with winch

NEW EUROPEAN STANDARDS & WINCHMASTER

New Harmonised European Standards: EN14492-1 for power driven winches, EN14492-2 for power driven hoists provide the means for conformity to essential Health and Safety requirements of the EC Machinery Directive.

Conformity to these standards is the joint responsibility of the supplier, the installer and the company operating the product.

CE Winchmaster products are fully compliant and carry a CE mark. A Declaration of Conformity is also supplied with each winch or hoist.

Selecting the correct winch or hoist for the application is very important not only from the health and safety aspect, but also to maximise product life and value for money.

Our aim at Winchmaster is to ensure the correct machine is supplied to suit the application and we welcome the opportunity of discussing the proposed application and offer advice. It will help us considerably if information regarding the maximum and average loads to be lifted or pulled - and approximate frequency of use can be provided.

For hoisting applications the minimum breaking force (MBF**) of the wire rope must be 5 x the lifting capacity of the hoist. The ratio of wire rope diameter to mean drum diameter* is usually at least 15:1. This will vary according to the application, the average operating time per day and the average and maximum weights being lifted.

For pulling applications (for example, in factories) as a general rule requires a wire rope with a MBF** relative to winch capacity of 3:1 and a rope to mean drum ratio* of 12:1.

For recovery vehicles the permissible standard of wire rope MBF** to winch rating can be a minimum 2:1 and the ratio of wire rope to mean drum ratio* only 10:1. This minimum standard is permitted because the running time is so short and the winch rarely sees maximum load.

Wire rope capacities the maximum amount of wire rope on the drum must leave a freeboard to the top of the drum flange of 1.5 x wire rope diameter to prevent the wire rope coming off the drum.

Winches and hoists with capacities over 1000kg must be load limited.

* Mean drum diameter = the drum diameter plus the diameter of the wire rope.

** MBF = the Minimum Breaking Force of the wire rope.

CWG LIFTING WINCHES 400-600kg

CWG10151 (400 - 480kg)

CWG30151 (400 - 600kg)

Rated on 3rd layer of rope

240v x 1ph or 415v x 3ph AC

FEATURES INCLUDE

- **Single or 3 phase options**
A choice of 240v or 415v across the range
- **Electromagnetic, spring applied, failsafe brake**
Provides instant, safe braking
- **Bi-rotational**
CWG winches can be installed with wire rope coming off the top or bottom of the drum
- **Enclosed drum flange**
Prevents rope becoming trapped between drum and support casing
- **Includes skid mounting frame**
- **Low voltage control supplied as standard**
For both 240v and 415v versions
24v AC, pre-wired to the winch with 2 button control and emergency stop
- **Complete with wire rope**
9mm x 41m, galvanised for longer life
- **Quiet running**
Conforms to noise pollution regulations
- **Cast steel foot mounting**
For easy installation
- **360° weighted safety hook**
Swivel type with safety catch
- **2 metre power lead**
Pre-wired to the winch with commercial type plug
- **Motor to IP54 as standard**
(other options available on request)

ADDITIONAL EQUIPMENT FROM WINCHMASTER

- **Radio remote control**
- **Weather proof enclosure**

TO ESTABLISH WHICH WINCH OR HOIST IS SUITABLE FOR YOUR PROJECT, CALL WINCHMASTER NOW ON 01482 223663

WINCHMASTER Unit 6 South Orbital Trading Park Hedon Road Hull HU9 1NJ

T: +44 (0)1482 223663 F: +44 (0)1482 218285

CALL SALES ON 01482 223663

E: sales@winchmaster.co.uk W: www.winchmaster.co.uk

A DIVISION OF
BHW
GROUP
LIMITED



CERT. No. 1769

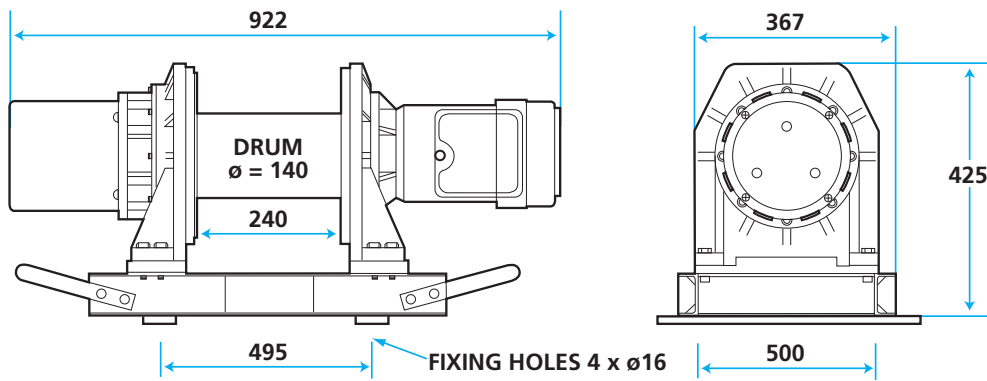

LINE PULL AND LINE SPEED PERFORMANCES - WINCHES ARE LOAD RATED ON THIRD LAYER

CWG10151a 240v x 1ph

		LAYERS				
		1	2	3	4	5
Maximum Rated Line Pull by Layer	kN kgf	4.9 500	4.5 454	3.9 400	3.6 372	3.5 360
CWG10151a Rope Capacity Cumulative by Layer (9mm Dia. Wire Rope)	m	13.2	27.3	42	57.5	73.6
Line Speed*	m/min	22	25.3	28	30.3	34

CWG10151b 240v x 1ph

		LAYERS				
		1	2	3	4	5
Maximum Rated Line Pull by Layer	kN kgf	5.9 600	5.2 530	4.7 480	4.3 435	3.9 400
CWG10151b Rope Capacity Cumulative by Layer (9mm Dia. Wire Rope)	m	13.2	27.3	42	57.5	73.6
Line Speed*	m/min	11.5	12.8	14	15.8	17.3

CWG30151 Series 415v x 3ph

		LAYERS 30151a				
		1	2	3	4	5
Maximum Rated Line Pull by Layer	kN kgf	4.9 500	4.4 450	3.9 400	3.4 350	2.9 300
CWG30151 Rope Capacity Cumulative by Layer (9mm Dia. Wire Rope)	m	13.2	27.3	42	57.5	73.6
Line Speed*	m/min	24	27	30	33.6	36.8

		LAYERS 30151b				
		1	2	3	4	5
Maximum Rated Line Pull by Layer	kN kgf	7.4 740	6.5 661	5.9 600	5.3 544	4.9 500
Rope Capacity Cumulative by Layer	m	13.2	27.3	42	57.5	73.6
Line Speed*	m/min	11.6	12.8	14.3	15.8	17.3

		LAYERS 30151c				
		1	2	3	4	5
Maximum Rated Line Pull by Layer	kN kgf	7.4 740	6.5 661	5.9 600	5.3 544	4.9 500
Rope Capacity Cumulative by Layer	m	13.2	27.3	42	57.5	73.6
Line Speed*	m/min	7.8	8.7	9.6	10.5	11.5

* Based on recommended 9mm diameter wire rope, 1960N/mm² grade, 7 x 18 wire core construction

CWG SPECIFICATIONS

	10151a	10151b	30151a	30151b	30151c
Voltage options:	240v 1ph		415v 3ph		
Lifting capacity	400kg	480kg	400kg	600kg	600kg
Weight: Winch only	120kg				
Total kit average	148kg				
Wire rope: ϕ x length	9mm x 42m				
Construction	7 x 18 wire core 1960N/mm ² grade. Minimum factor of safety 5:1				
Motor type:	Induction motor				
Outputs: Kilowatts	2.2kw	1.5kw	2.2kw	1.5kw	1.5kw
Amperes	14.5amp	10.6amp	4.6amp	3.5amp	2.9amp
Braking:	Electromagnetic spring applied failsafe				
Drum & flange dimensions:	240mm length, drum ϕ = 140mm, flange ϕ = 280mm				
	Rope ϕ to mean drum ϕ ratio:16.5:1				

NOTES

These winches must not be used for the movement of personnel and 7 wraps of wire rope must be maintained on the drum.

Data shown is approximate and intended as a guide only.

WARRANTY

Each new winch is guaranteed against defects in workmanship and material defects for a period of twelve months from date of purchase.

WIRE ROPES ARE NOT INCLUDED UNDER WARRANTY.

WINCHMASTER Unit 6 South Orbital Trading Park Hedon Road Hull HU9 1NJ

T: +44 (0)1482 223663 F: +44 (0)1482 218285

A DIVISION OF
BHW
GROUP
LIMITED

CALL SALES ON 01482 223663
E: sales@winchmaster.co.uk W: www.winchmaster.co.uk

WINCHMASTER IS A DIVISION OF THE BHW GROUP LIMITED REGISTERED IN ENGLAND No. 1342461

WM18/20.02.09



CERT. No. 1769