

WinchMaster

SPECIALIST WINCH SOLUTIONS

COMPLIANT WITH EN 14492 REGULATIONS

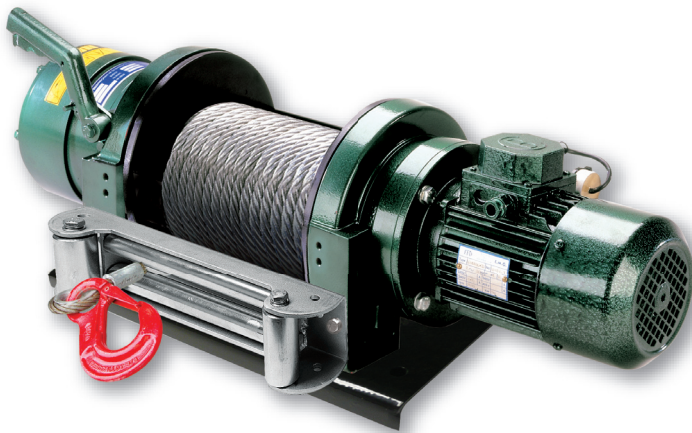

NEW EUROPEAN STANDARDS & WINCHMASTER

New Harmonised European Standards: EN14492-1 for power driven winches, EN14492-2 for power driven hoists provide the means for conformity to essential Health and Safety requirements of the EC Machinery Directive.

Conformity to these standards is the joint responsibility of the supplier, the installer and the company operating the product.

CE Winchmaster products are fully compliant and carry a CE mark. A Declaration of Conformity is also supplied with each winch or hoist.

Selecting the correct winch or hoist for the application is very important not only from the health and safety aspect, but also to maximise product life and value for money.

Our aim at Winchmaster is to ensure the correct machine is supplied to suit the application and we welcome the opportunity of discussing the proposed application and offer advice. It will help us considerably if information regarding the maximum and average loads to be lifted or pulled - and approximate frequency of use can be provided.

For hoisting applications the minimum breaking force (MBF**) of the wire rope must be 5 x the lifting capacity of the hoist. The ratio of wire rope diameter to mean drum diameter* is usually at least 15:1. This will vary according to the application, the average operating time per day and the average and maximum weights being lifted.

For pulling applications (for example, in factories) as a general rule requires a wire rope with a MBF** relative to winch capacity of 3:1 and a rope to mean drum ratio* of 12:1.

For recovery vehicles the permissible standard of wire rope MBF** to winch rating can be a minimum 2:1 and the ratio of wire rope to mean drum ratio* only 10:1. This minimum standard is permitted because the running time is so short and the winch rarely sees maximum load.

Wire rope capacities the maximum amount of wire rope on the drum must leave a freeboard to the top of the drum flange of 1.5 x wire rope diameter to prevent the wire rope coming off the drum.

Winches and hoists with capacities over 1000kg must be load limited.

* Mean drum diameter = the drum diameter plus the diameter of the wire rope.
** MBF = the Minimum Breaking Force of the wire rope.

AC 3000 SERIES Pulling Winch with Freespool 3000kg & 4000kg

AC3000a (3000kg), AC3000b (4000kg)
415v x 3ph AC

FEATURES INCLUDE

- **Freespool clutch**
Enables easy unspooling of wire rope
- **Braked motor**
Provides instant, safe braking
- **Heavy duty mounting plate and roller guide**
For quick and simple installation
- **3 metre pendant control**
Low voltage 24v in the handset – Includes Emergency stop and 3m cable pre-wired to the winch as standard
- **Motor to IP54 as Standard**
(Other options available on request)
- **2 metre power lead**
Pre-wired to the winch with commercial type plug

ADDITIONAL EQUIPMENT FROM WINCHMASTER

- **Wire rope**
- **Skid mounting frame**
- **Tension roller**
- **Weather proof enclosure**
- **Radio remote control**

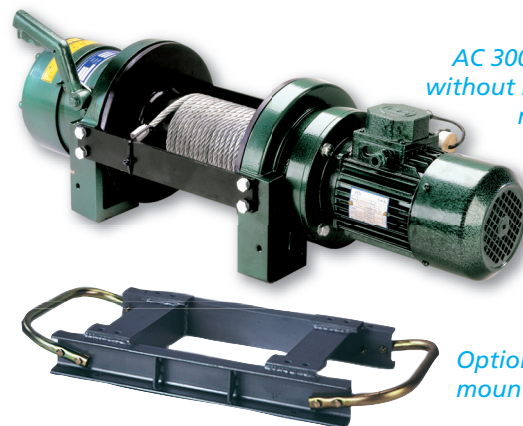

AC 3000 series shown without roller guides or mounting plate

Optional skid mounting frame

Special machines can be built to meet customers' requirements. Example:

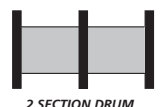

TO ESTABLISH WHICH WINCH OR HOIST IS SUITABLE FOR YOUR PROJECT, CALL WINCHMASTER NOW ON 01482 223663

WINCHMASTER Unit 6 South Orbital Trading Park Hedon Road Hull HU9 1NJ
T: +44 (0)1482 223663 F: +44 (0)1482 218285

A DIVISION OF
BHW
GROUP
LIMITED

CALL SALES ON 01482 223663
E: sales@winchmaster.co.uk W: www.winchmaster.co.uk



CERT. No. 1769

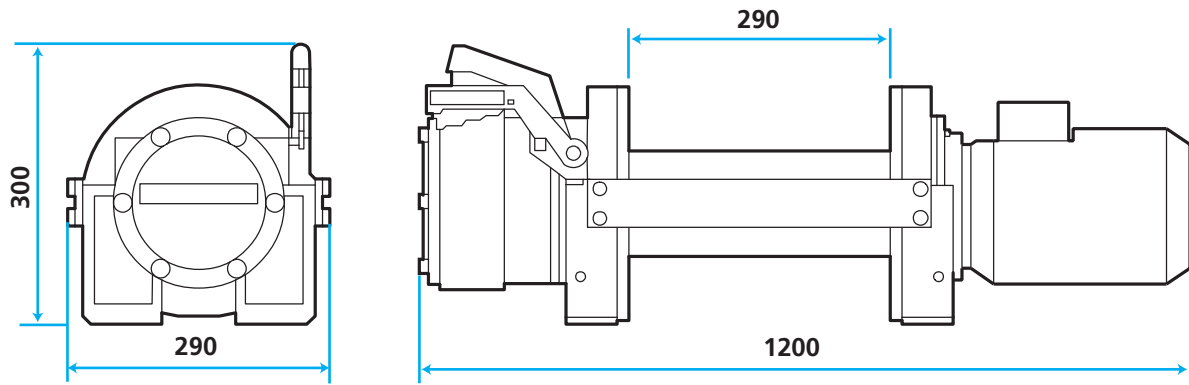

LINE PULL AND LINE SPEED PERFORMANCES

AC3000a

		LAYER			
		1	2	3	4
Maximum Rated Line Pull by Layer	kN	29.4	26.5	23.8	17.6
	kgf	3000	2700	2430	1800
AC3000a Rope Capacity Cumulative by Layer (12mm Dia. Wire Rope)	m	9.8	21	33	46
Line Speed*	m/min	3.3	3.6	4.1	5.3

* Based on recommended 12mm wire rope, 1960N/mm² grade, 6 x 36 wire core construction

AC3000b

		LAYER			
		1	2	3	4
Maximum Rated Line Pull by Layer	kN	39.2	35.3	31.4	27.5
	kgf	4000	3600	3200	2800
AC3000b Rope Capacity Cumulative by Layer (13mm Dia. Wire Rope)	m	9	19	31	43
Line Speed*	m/min	3.3	3.6	4.1	5.3

* Based on recommended 13mm wire rope, 1960N/mm² grade, 6 x 36 wire core construction

SPECIFICATIONS

AC3000a

AC3000b

Voltage:	415v 3ph	415v 3ph
Weight: Winch only	65kg	65kg
	Total kit average	95kg
Motor:	Induction braked	
Outputs: Kilowatts	3kw	4kw
	Amperes	6.6amp
Braking:	Electronic	
Drum & flange dimensions:	290mm length, drum \varnothing = 125mm, flange \varnothing = 260mm	
Wire rope: Diameter	12mm	13mm
Maximum length on drum:	46 metres*	43 metres*
Wire rope construction:	1960N/mm ² grade, 6x36 wire core for maximum flexibility. Factor of safety 3:1	
Rope \varnothing to mean drum \varnothing ratio:	11.4:1	10.6:1

* Choices of wire rope lengths, up to the maximum shown, are available on request

NOTES

These winches must not be used for the movement of personnel and 7 wraps of wire rope must be maintained on the drum.

Data shown is approximate and intended as a guide only.

WARRANTY

Each new winch is guaranteed against defects in workmanship and material defects for a period of twelve months from date of purchase.

WIRE ROPES ARE NOT INCLUDED UNDER WARRANTY.