

# WinchMaster

SPECIALIST WINCH SOLUTIONS

COMPLIANT WITH EN 14492 REGULATIONS



## CHAIN HOISTS 500-1000kg DU901 (500kg), DU902 (1000kg)

Available as either 110v or 240v x 1ph AC

*Lightweight versatile chain hoists offering excellent performance for such compact machines.*

*These professional jobbing hoists are a 'must have' for all service vans. Ideal for Civil Contractors, Builders and Factory Service Engineers.*

*Portable, saves time and effort - and a major contribution to maintaining Health and Safety standards on site.*

### FEATURES INCLUDE

- **Available in either 110v or 240v x 1ph options**  
*In the case of 110v version - via transformer*
- **Lightweight and compact design**  
*Easy installation, ideal for moving between different locations*
- **Safety slipping clutch**  
*Prevents hook becoming trapped into the hoist in the 'up' direction*
- **Supplied with chain bag**  
*For safe storage of chain - please ask about relevant capacities for length of chain required*
- **360° safety hook**  
*Self latching swivel type*
- **10 metre plug in pendant control**  
*2 button plus emergency stop*
- **3 metre power lead with commercial type 3 pin plug**
- **Limited motor draw on amperage**  
*Rectified brush type limits current draw to 6 amps. This enables hoist to operate from a standard 13amp ring main*

### NEW EUROPEAN STANDARDS & WINCHMASTER

**New Harmonised European Standard EN14492-2 for power driven hoists** provides the means for conformity to essential Health and Safety requirements of the EC Machinery Directive.

**Conformity to these standards** is the joint responsibility of the supplier, the installer and the company operating the product.

**CE** Winchmaster products are fully compliant and carry a CE mark. A Declaration of Conformity is also supplied with each winch or hoist.

**Selecting the correct winch or hoist** for the application is very important not only from the health and safety aspect, but also to maximise product life and value for money.

**Our aim at Winchmaster** is to ensure the correct machine to suit the application is supplied and we welcome the opportunity of discussing the proposed application and offer advice. It will help us considerably if information regarding the maximum and average loads to be lifted - and approximate frequency of use can be provided.

**TO ESTABLISH WHICH CHAIN HOIST IS SUITABLE FOR YOUR PROJECT, CALL WINCHMASTER NOW ON 01482 223663**

### ADDITIONAL EQUIPMENT

- **Chains**  
*Chains are sold separately -subject to customer requirements. The maximum height of lift is 16m for the DU901 and 8m for the DU902.*  
*For greater lift heights an alternative chain bag is required, please speak with Winchmaster sales for more information.*

**WINCHMASTER** Unit 6 South Orbital Trading Park Hedon Road Hull HU9 1NJ  
T: +44 (0)1482 223663 F: +44 (0)1482 218285

**CALL SALES ON 01482 223663**  
E: [sales@winchmaster.co.uk](mailto:sales@winchmaster.co.uk) W: [www.winchmaster.co.uk](http://www.winchmaster.co.uk)

A DIVISION OF  
**BHW**  
GROUP  
LIMITED



CERT. No. 1769

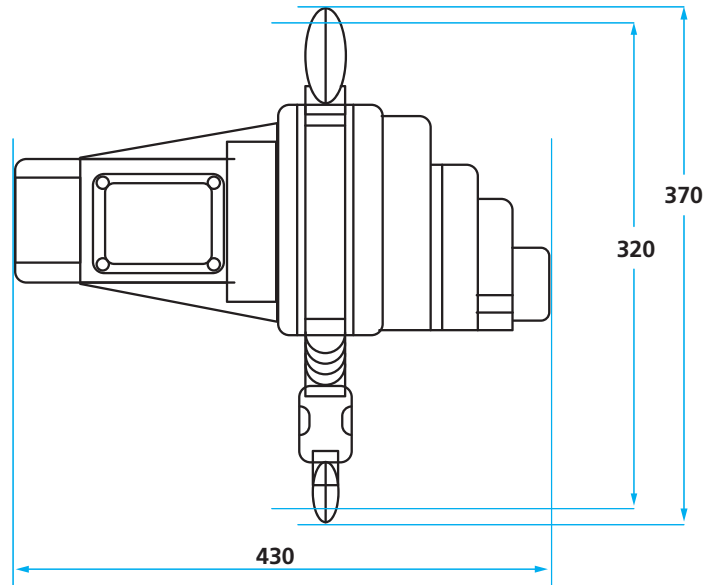
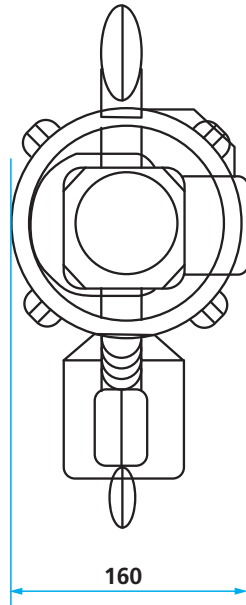

## SPECIFICATIONS

### DU901

### DU902

Voltage:		110v	240v	110v	240v
Lifting:	Capacity	500kg		1000kg	
	Height*:	16m		8m	
	Type of fall:	Single		Double	
Weight:	Hoist only	9kg		14kg	
	Total kit	20kg		24kg	
Line speed approx		6m/min		3m/min	
Outputs	Kilowatts:	1.3kw		1.3kw	
	Amperes:	12amp	6amp	12amp	6amp
Duty cycle:		All Chain Hoists have a duty cycle of 25%, with a maximum of 60 starts per hour			
Chain:		Grade 80 HT galvanised - Links 6.3mm dia x 19.1mm long			

\* The lifting heights shown are the maximum using the standard chain storage bag. For other options, please contact Winchmaster sales.

## NOTES

Please ensure that the fixing point for these hoists are capable of supporting the loads required.

These hoists must not be used for the movement of personnel.

Data shown is approximate and intended as a guide only.

## WARRANTY

Each new hoist is guaranteed against defects in workmanship and material defects for a period of twelve months from date of purchase.

**CHAINS ARE NOT INCLUDED UNDER WARRANTY.**

**WINCHMASTER** Unit 6 South Orbital Trading Park Hedon Road Hull HU9 1NJ

T: +44 (0)1482 223663 F: +44 (0)1482 218285

A DIVISION OF  
**BHW**  
**GROUP**  
**LIMITED**

**CALL SALES ON 01482 223663**  
E: [sales@winchmaster.co.uk](mailto:sales@winchmaster.co.uk) W: [www.winchmaster.co.uk](http://www.winchmaster.co.uk)

WINCHMASTER IS A DIVISION OF THE BHW GROUP LIMITED REGISTERED IN ENGLAND No. 1342461

WM25/04.03.09



CERT. No. 1769