

WinchMaster

SPECIALIST WINCH SOLUTIONS

COMPLIANT WITH EN 14492-1 REGULATIONS*

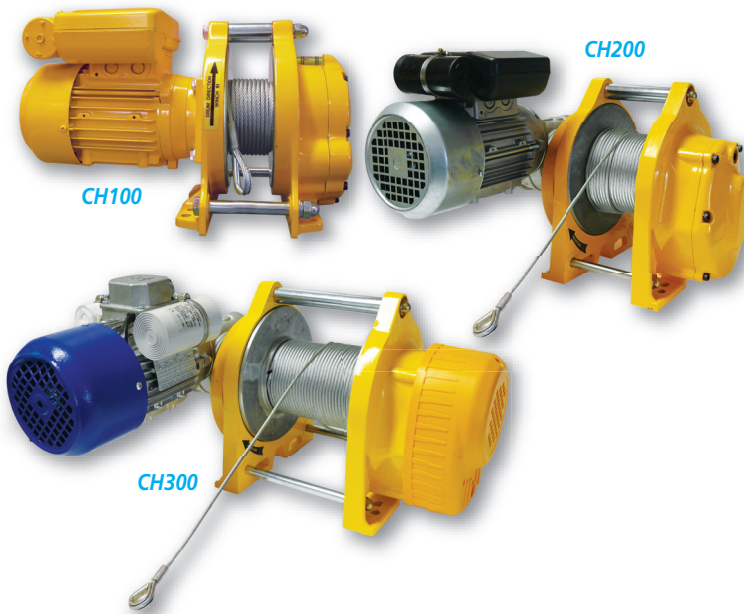

CHANDELIER HOIST SYSTEMS 100-300kg Lifting Capacity

**CH100 (100kg), CH200 (200kg)
CH300 (300kg)**

240v x 1ph AC

FOR LIFTING AND LOWERING CHANDELIERS AND OTHER SUSPENDED FIXTURES

Situated in the ceiling void or a suitable area, these hoists have been designed specifically to enable lifting and lowering of chandeliers and other suspended fixtures for safe and easy maintenance.

Built to the highest standards to ensure reliability and minimum maintenance, the hoists will safely and securely hold the fixture in place.

Supplied with spin resistant wire rope.

A double pulley system can enable repairs or maintenance without disconnecting power supply.

Can be calibrated to stop at full ceiling height and preferred lowered position.

HOIST FEATURES INCLUDE:

- **A choice of three hoists - 100kg, 200kg or 300kg lifting capacity**
*With different capacities for heights of lift
Larger hoists for heavier duty can also be supplied*
- **Operates on standard 240v household supply**
- **Efficient load holding**
Dual braking - independent ratchet brake running in oil and electromagnetic motor brake
- **Lightweight and compact design**
Aluminium die-castings to save weight and the compact design enables installation in small roof voids
- **Available in different drum lengths**
To provide choice for wire rope length
- **Enclosed drum flange**
Prevents the wire rope becoming trapped between the drum and support casing
- **Smooth running gearbox**
Quiet and efficient spur gearbox

Choice of motor position

CH200 and CH300 motors can be mounted in any of the three positions shown to suit the space available.

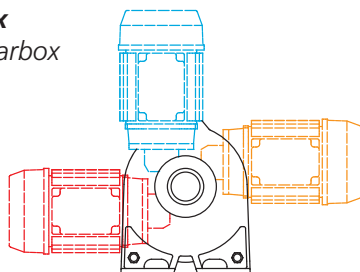

**TO ESTABLISH WHICH HOIST IS SUITABLE FOR
YOUR PROJECT, CALL US NOW ON 01482 223663
LARGER SIZES OF CHANDELIER HOISTS
CAN ALSO BE MADE BY WINCHMASTER**

HOIST LIFTING SYSTEMS INCLUDE:

- **Fully pre-wired control box**
For easy electrical installation - complete with contactors and numbered termination blocks
- **'Key only' access control switch**
For additional security and safety
- **Double pulley, for the hoist and power cable**
Power can remain connected to the fixture and cable will simply pay out from the automatic cable rewriter
- **Single pulley - for hoist only applications**
When power is not connected, or fixture only requires wire rope
- **Rotational limit switch with upper and lower stop settings**
Calibrated by the installer to suit individual installation
- **Automatic power cable rewriter**
Certified as suitable for the application (The kw rating and circuit details of the light fitting should be specified to Winchmaster at the time of order)
- **Non rotating wire rope supplied to correct length**
This is calibrated by Winchmaster to allow for winch requirements and the distance from floor to ceiling
- **Protection covers**
To protect the hoist, pulleys or cable rewriters from falling debris or dust

LINE PULL AND LINE SPEED PERFORMANCES

CH100

Rated lifting capacity
100kg on 4th layer

		NUMBER OF ROPE LAYERS ON DRUM							
		1	2	3	4	5	6	7	8
Maximum Rated Line Pull by Layer	kN	1.3	1.2	1.1	0.9	0.9	0.8	0.8	0.7
	kg	135	121	110	100	92	86	80	75
Rope Capacity Cumulative by Layer (4mm Ø Wire Rope)	m	2.5	5.4	8.5	11.9	15.5	19.5	23.8	28.3
Line Speed - m/min		3.5	4.0	4.5	5.1	5.6	6.1	6.6	7.1

Will provide approximately 27m lift with 75kg lifting capacity on 8th layer
(Wire rope uses 1.5m to secure a minimum of 7 wraps on the drum at all times)

CH200

Rated lifting capacity
200kg on 3rd layer

		NUMBER OF ROPE LAYERS ON DRUM							
		1	2	3	4	5	6	7	8
Maximum Rated Line Pull by Layer	kN	2.4	2.2	2.0	1.8	1.7	1.6	1.5	1.4
	kg	243	220	200	185	171	159	149	140
Rope Capacity Cumulative by Layer (5mm Ø Wire Rope)	m	5.8	12.2	19.2	27	35	44	53	63
Line Speed - m/min		3.5	3.9	4.3	4.7	5.0	5.4	5.8	6.1

Will provide approximately 60m lift with 140kg lifting capacity on 8th layer
(Wire rope uses 1.5m to secure a minimum of 7 wraps on the drum at all times)



CH300

Rated lifting capacity
300kg on 3rd layer

		NUMBER OF ROPE LAYERS ON DRUM							
		1	2	3	4	5	6	7	8
Maximum Rated Line Pull by Layer	kN	3.6	3.2	2.9	2.7	2.5	2.3	2.2	2.0
	kg	364	329	300	277	256	238	223	210
Rope Capacity Cumulative by Layer (5mm Ø Wire Rope)	m	8.8	18.5	29.1	40.6	53	66.5	81	96
Line Speed - m/min		2.4	2.6	2.9	3.1	3.4	3.6	3.9	4.1

Will provide over 90m lift with 210kg lifting capacity on 8th layer
(Wire rope uses 1.5m to secure a minimum of 7 wraps on the drum at all times)

SPECIFICATIONS

CH100

CH200

CH300

Voltage:	All models are 240v x 1ph and will operate on a domestic supply		
Winch only weight:	9kg	30kg	40kg
Average total kit weight:	11kg	32kg	42kg
Motor type:	Induction motor		
Outputs	Kilowatts:	0.18kw	0.37kw
	Amperes:	1.6amp	3.6amp
Braking:	Dual mechanical and electromagnetic motor brake		
Drum	Diameter:	70mm	95mm
	Length:	46mm	97mm
	Flange ø:	158mm	190mm
Wire rope	Diameter:	4mm	5mm
	Construction:	18 x 7 spin resistant wire rope 1960N/mm ² MBL 10.3kN	19 x 7 spin resistant wire rope 1960N/mm ² MBL 16.08kN
Rope ø to mean drum ø ratio:	18:1	20:1	20:1
Minimum recommended distance of winch from pulley over ceiling rose:	500mm	1100mm	1650mm

Before installing any hoist system, it is important to work out what possible stress may be put onto the adjacent ceiling joists. A suitable support must be fitted across the joists to spread the load. If in doubt, consult a builder or structural engineer.

NOTES

These winches must not be used for the movement of personnel and 7 wraps of wire rope must be maintained on the drum.

Data shown is approximate and intended as a guide only.

WARRANTY

Each new winch is guaranteed against defects in workmanship and material defects for a period of twelve months from date of purchase.

WIRE ROPES ARE NOT INCLUDED UNDER WARRANTY.

WINCHMASTER Unit 6 South Orbital Trading Park Hedon Road Hull HU9 1NJ

T: +44 (0)1482 223663 F: +44 (0)1482 218285



CALL SALES ON 01482 223663
E: sales@winchmaster.co.uk W: www.winchmaster.co.uk

WINCHMASTER IS A DIVISION OF THE BHW GROUP LIMITED REGISTERED IN ENGLAND No. 1342461

WM34/27.02.09



CERT. No. 1769

TYPICAL INSTALLATION LAYOUT

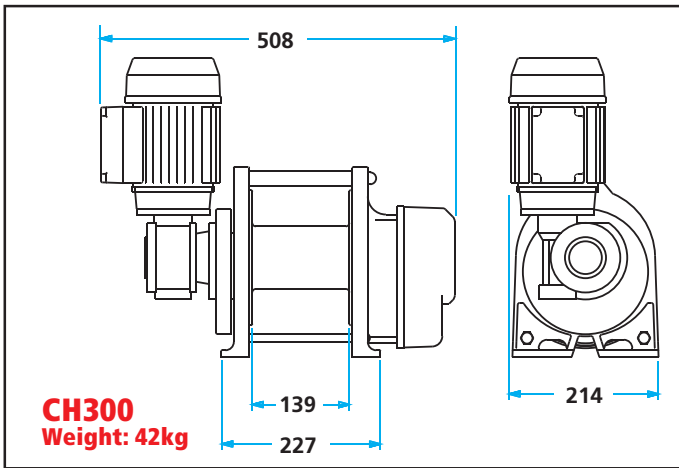
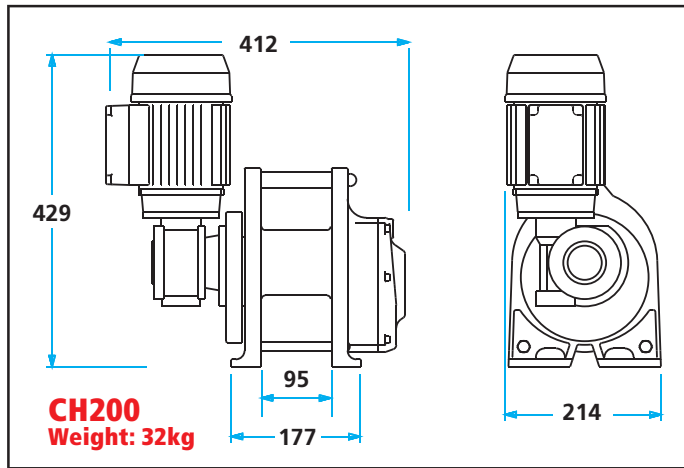
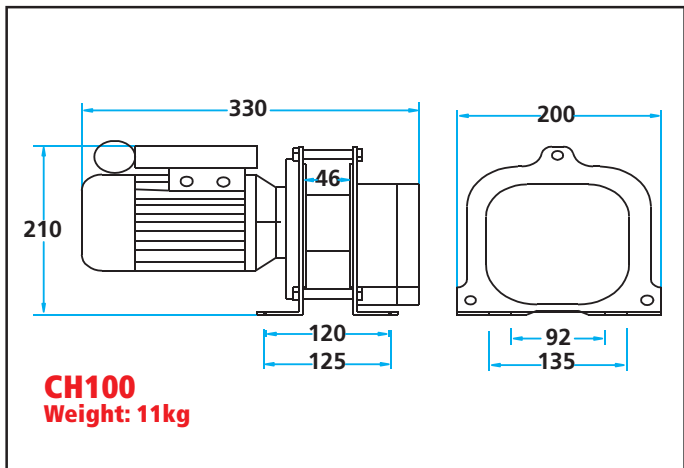
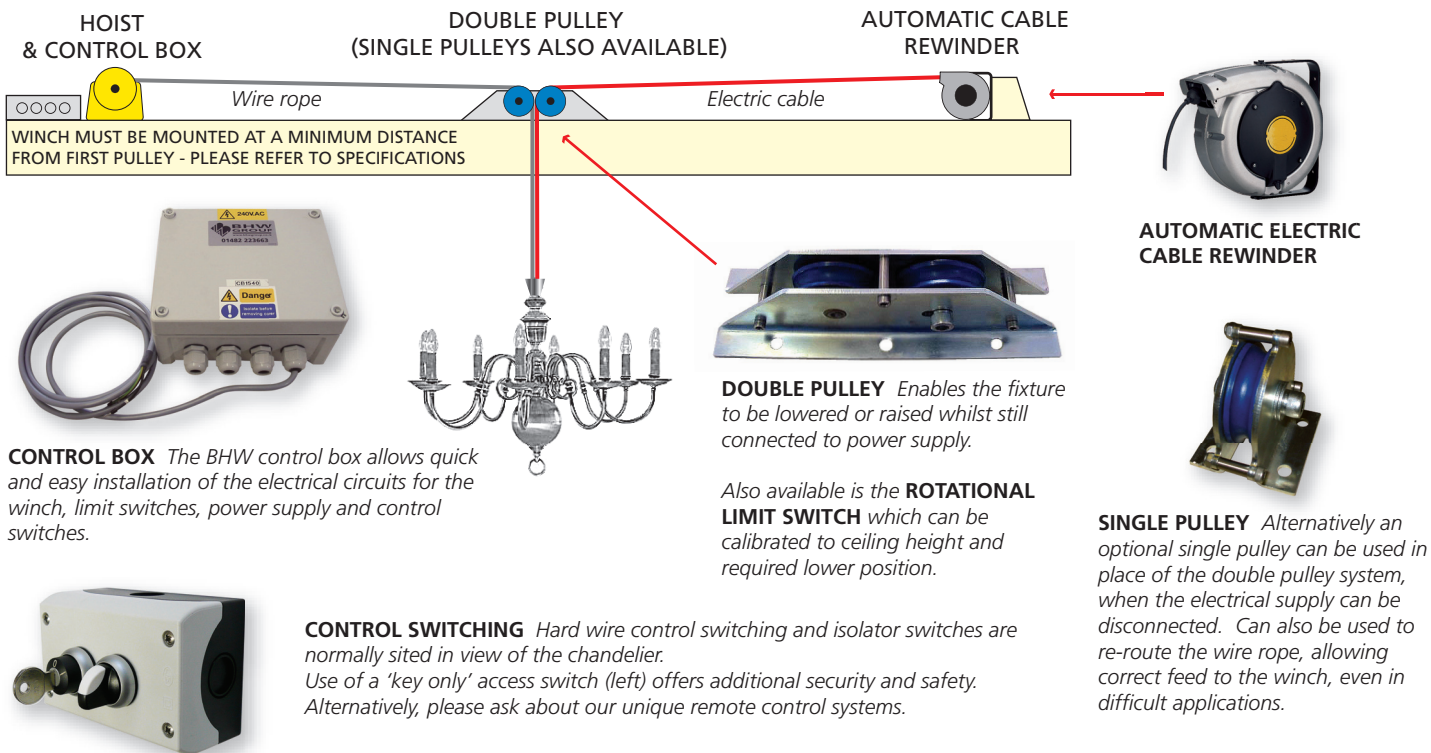

WINCHMASTER Unit 6 South Orbital Trading Park Hedon Road Hull HU9 1NJ
T: +44 (0)1482 223663 F: +44 (0)1482 218285



CALL SALES ON 01482 223663
E: sales@winchmaster.co.uk W: www.winchmaster.co.uk

WINCHMASTER IS A DIVISION OF THE BHW GROUP LIMITED REGISTERED IN ENGLAND No. 1342461

WM34/27.02.09



CERT. No. 1769